

SECTION 9

SPECIFICATIONS AND STANDARDS DETAILS

E-STND	EASEMENT STANDARDS
G-NOTE	GENERAL NOTES
R-BLK	REVIEW BLOCK
S-1	TYPICAL SANITARY
S-2	BASE CHANNELIZATION
S-3	MANHOLE
S-4	MANHOLE RING AND COVER
S-5	MANHOLE STEPS
S-6	DROP MANHOLE
S-7	DOMESTIC SEWER TAP
S-8	KNOCK-OUT MANHOLE

DRAWING LOCATION: G:\Willis\14.0350-Southwest_Suburban_Denver_WSD\BASE_DETAILS\KARRISA_NOTES.dwg

NO.	REVISIONS	DATE	BY
1	GENERAL	7/14	JVM



SOUTHWEST SUBURBAN DENVER WATER AND SANITATION DISTRICT EASEMENT STANDARDS

THE FOLLOWING ITEMS ARE MINIMUM REQUIREMENTS FOR REAL PROPERTY DESCRIPTIONS FOR ALL EASEMENTS PROVIDED TO THE SOUTHWEST SUBURBAN DENVER WATER AND SANITATION DISTRICT. WE ASK THAT YOU BE FAMILIAR WITH OUR NEEDS AS STATED BELOW.

1. BEARINGS AS RECITED IN THE WRITTEN DESCRIPTION MUST SHARE THE SAME DIRECTION IN THE ACCOMPANYING SKETCH.
2. EACH "COURSE" MUST BE SEPARATED BY THE WORD THENCE.
3. IF A "COURSE" LIES COINCIDENT WITH A LINE OF "RECORD," SO STATE.
4. THE END OF A LINE (LINES) ON A LINE OF "RECORD," SO STATE.
5. PROVIDE BASIS OF BEARINGS. IF YOUR BASIS OF BEARING CHANGES DURING YOUR DESCRIPTIONS, SO STATE.
6. PROVIDE A POINT OF BEGINNING OR POINT OF COMMENCEMENT, AS APPROPRIATE.
7. PROVIDE A TRUE POINT OF BEGINNING OR TRUE POINT OF COMMENCEMENT, AS APPROPRIATE.
8. DO NOT STATE THAT THE EASEMENT IS "X" FEET WIDE UNLESS THIS IS TRUE THROUGHOUT THE DESCRIPTION.
9. IF CREATING MULTIPLE EASEMENT PARCELS THAT ARE INTENDED TO JOIN ONE ANOTHER, THERE MUST BE A CONCLUSIVE "TIE" INDICATING THAT SUCH IS THE CASE.
10. PROVIDE PAGINATION WHEN APPROPRIATE.
11. IF INSTRUMENTS OF "RECORD" ARE RECITED, THEIR LOCATION MUST BE INCLUDED, I.E. COUNTY SEAT.
12. DESCRIPTIONS MUST BE TIED TO A SECTION CORNER. INCLUDE A PHYSICAL DESCRIPTION OF THE MONUMENT, AND STATE WHETHER FOUND OR SET.
13. PROVIDE YOUR NAME, COMPANY, ADDRESS AND PHONE NUMBER ALONG WITH PLS SIGNATURE AND SEAL AT THE END OF THE WRITTEN DESCRIPTION.
14. WRITTEN DESCRIPTIONS AND SKETCHES ARE BOTH PREFERRED ON 8 1/2"X 11" FORMAT.
15. AREA OF THE PARCEL IS TO BE EXPRESSED IN SQUARE FEET AND ACRES.

WHEN REVIEWING SUBMITTED DESCRIPTIONS AND SKETCHES, WE ARE LOOKING FOR CLARITY, BREVITY AND UNIQUELY LOCATABLE REAL PROPERTY PARCELS.

DRAWING LOCATION: G:\Willis\14.0350-Southwest-Suburban-Denver-WSD\BASE\DETAILS\KARRISA\nOTES.dwg

NO.	REVISIONS	DATE	BY
1	GENERAL	7/14	JVM



SOUTHWEST SUBURBAN DENVER WATER & SANITATION DISTRICT GENERAL NOTES

GENERAL

1. ALL SANITARY SEWER WORK SHALL BE IN ACCORDANCE WITH THE SOUTHWEST SUBURBAN DENVER WATER & SANITATION DISTRICT'S SPECIFICATIONS AND THOSE OF THE WASTEWATER MANAGEMENT DIVISION. ADDITIONALLY, DRAINAGE, SEWER, UTILITY AND RELATED CASTINGS MUST MEET AASHTO DESIGNATION M 306-05 WHICH INCLUDE THE REFERENCE DOCUMENTS AASHTO M 105, ASTM A 48, A 536 AND B 26, AND FEDERAL SPECIFICATION CID A-A-60005, FRAMES, COVERS, GRATINGS, STEPS, SUMP AND CATCH BASIN MANHOLE. IF THE SOUTHWEST SUBURBAN DENVER WATER AND SANITATION DISTRICT'S STANDARD NOTES OR DETAILS ARE IN CONFLICT WITH THE WASTEWATER MANAGEMENT DIVISION (WMD), WASTEWATER MANAGEMENT DIVISION STANDARDS APPLY WITH THE EXCEPTION OF:
 - A. ECCENTRIC CONES SHALL BE USED FOR ALL SANITARY SEWER MANHOLES. A CUT-OFF WALL SHALL BE PLACED AT THE PROPERTY LINE OF ALL SANITARY SEWER SERVICES.
 - B. ALL SANITARY MANHOLE LIDS ARE REQUIRED TO BE IDENTIFIED AS SEWER OR SANITARY

THE DETAILS PROVIDED WITHIN THIS PLAN SET ARE PROVIDED FOR CONVENIENCE DURING CONSTRUCTION. THE CONTRACTOR SHALL MAINTAIN A COPY OF THE WASTEWATER MANAGEMENT DIVISION STANDARD DETAILS ON THE SITE AT ALL TIMES. THE WASTEWATER MANAGEMENT DIVISION DETAILS SHALL BE USED IN THE EVENT OF A DISCREPANCY.

2. ALL WORK PERFORMED WITHIN THE PUBLIC RIGHT-OF-WAY SHALL CONFORM TO CONSTRUCTION SPECIFICATIONS AND DESIGN STANDARDS FOR THE LOCAL JURISDICTION. IN ADDITION, AND WORK PERFORMED WITHIN THE PUBLIC RIGHT-OF-WAY WILL OBTAIN THE APPLICABLE STATE, COUNTY OR CITY CONSTRUCTION PERMIT.
3. AT LEAST 48 HOURS IN ADVANCE OF BEGINNING CONSTRUCTION, THE CONTRACTOR IS RESPONSIBLE TO NOTIFY THE UTILITY NOTIFICATION CENTER OF COLORADO AT 1-800-922-1987 FOR LOCATION OF UNDERGROUND UTILITIES. THE CONTRACTOR SHALL ALSO NOTIFY THE SOUTHWEST SUBURBAN DENVER WATER DISTRICT AT 303-674-3379 TO ALLOW FOR SCHEDULING OF CONSTRUCTION OBSERVATION. THE CONTRACTOR SHALL REPLACE A: DISTURBED BURIED UTILITIES AND SURFACE IMPROVEMENTS TO THEIR ORIGINAL CONDITION WHETHER SHOWN ON THE PLANS OR NOT.
4. DURING CONSTRUCTION ACTIVITY, THE CONTRACTOR SHALL HAVE AT THE JOB SITE AT ALL TIMES ONE COPY OF THE PLANS SIGNED BY THE DISTRICT.
5. HORIZONTAL AND VERTICAL CONTROL: ALL SURVEY WORK SHALL BE TIED TO SECTION CORNERS AND RECOGNIZE VERTICAL DATUM. THE FOLLOWING BENCHMARKS SHALL BE USED.

BENCHMARK Q 409 ELEVATION= 5540.69 SET BY NGS IN 1984

IN THE COLUMBINE HILLS SUBDIVISION, AT THE JUNCTION OF SOUTH WADSWORTH BOULEVARD AND WEST BOWLES AVENUE, 49.1 METERS (161.1 FT) SOUTHEAST OF THE CENTERLINE OF THE EAST END OF A 5.0 FT METAL CULVERT, 20.4 METERS (66.9) FT EAST OF THE CENTERLINE OF THE NORTH BOUND LANES OF THE BOULEVARD, AND 17.7 METERS (58.1 FT) SOUTHEAST OF THE SOUTH END OF A GUARDRAIL. NOTE: ACCESS TO THE DATUM POINT IS THROUGH A 5-INCH LOGO CAP. A STAINLESS STEEL ROD SET TO THE DEPTH OF 10.7 METERS ENCASE IN A PIPE FLUSH WITH THE GROUND, 0.9 METERS BELOW THE BOULEVARD, 0.3 METERS WEST FROM A WITNESS POST AND FENCE.

CONSTRUCTION

1. PRIOR TO CONSTRUCTION THE CONTRACTOR SHALL INSTALL A TEMPORARY PIPE PLUG IN THE DOWNSTREAM END OF THE TIE-IN MANHOLE FOR THE NEW SEWER. THE PIPE PLUG MUST BE SECURED TO THE FIRST STEP OF THE MANHOLE TO PREVENT PLUG FROM MOVING OUT OF REACH. ALL MUD AND DEBRIS MUST BE REMOVED FROM THE NEW PIPE AND MANHOLE PRIOR TO CONNECTING IT TO THE EXISTING SYSTEM
2. THE CONTRACTOR SHALL VERIFY ELEVATIONS, BASED ON THE DISTRICT BENCHMARK LISTED ABOVE, OF EXISTING SEWERS AT POINTS OF CONNECTION PRIOR TO CONSTRUCTION OR STAKING OF SANITARY SEWER.

3. PIPE MATERIAL SHALL BE SEAMLESS OPEN PROFILE PIPE MEETING THE REQUIREMENTS OF ASTM F794 OR CLOSED PROFILE PIPE MEETING ASTM D30034 FOR SEWER PIPE. ACCEPTABLE PRODUCTS INCLUDE PVC PIPE (SDR 35) AND ULTRA-RIB PVC GRAVITY SEWER PIPE. JOINTS SHALL BE INTEGRAL BELL AND SPIGOT WITH RUBBER GASKET. CONTRACTOR SHALL FOLLOW MANUFACTURER'S INSTALLATION INSTRUCTION. PIPE SHALL BE ADDED IN CLASS B BEDDING MATERIAL
4. ALL PRECAST MANHOLE SECTIONS, FLAT TOPS, BARRELS, REDUCERS, ECT., SHALL CONFORM TO ASTM C-478 STANDARD SPECIFICATION FOR PRECAST REINFORCED MANHOLE SECTIONS.
5. FLAT TOP SECTIONS SHALL BE DESIGNED FOR HS-20 LOADING. SHALL BE PLACED WHERE GROUNDWATER IS VISIBLE OR UNTIL THE GROUNDWATER TABLE HAD BEEN LOWERED BELOW THE PROPOSED IMPROVEMENTS. ANY UNSTABLE AREAS AS A RESULT OF GROUNDWATER IMPROVEMENTS SHALL BE STABILIZED AS AGREED UPON BY THE CONTRACTOR, THE DISTRICT AND THE DESIGN ENGINEER AT THE TIME OF THEIR OCCURRENCE.
6. TRENCHES ARE TO BE SLOPED OR BRACED AND SHEETED AS NECESSARY FOR THE SAFETY OF THE WORKMEN AND PROTECTION OF OTHER UTILITIES IN COMPLIANCE WITH APPLICABLE STATE AND FEDERAL REGULATIONS. THE OWNER, DISTRICT, DISTRICT ENGINEER OR DESIGN ENGINEER IS NOT RESPONSIBLE FOR SAFETY IN, ON OR ABOUT THE PROJECT SITE NOR FOR THE COMPLIANCE BY THE APPROPRIATE PARTY OF ANY REGULATIONS RELATING THERETO.

7. ALL SHALL BE COMPACTED TO THE STANDARDS ESTABLISHED BY THE AUTHORITY HAVING JURISDICTION. WHERE NO STANDARDS EXISTS THE FOLLOWING MINIMUM SHALL BE USED FOR TRENCH COMPACTION: PAVED AREAS- 95% STANDARD PROCTOR UNPAVED/LANDSCAPE AREAS- 90% STANDARD PROCTOR.

8. MANHOLE RIM ELEVATIONS SHOWN ON DRAWINGS ARE APPROXIMATE ONLY. RIM ELEVATIONS SHALL BE ADJUSTED TO FINAL GRADE USING A MAXIMUM OF 12 INCHES COMPOSED OF THREE OR FEWER RINGS. FINAL RIM ELEVATIONS SHALL BE SET AS FOLLOWS:

- PAVED AREAS: 0 TO 1" BELOW SURROUNDING PAVEMENT SURFACE
- MOWED GRASS AREAS: 0 TO 1" ABOVE SURROUNDING SOIL SURFACE
- OTHER AREAS: 2" TO 6" ABOVE SURROUNDING SURFACES

FINAL ACCEPTANCE

1. IN PUBLIC RIGHT-OF-WAY, COMPACTION OF ALL TRENCH BACKFILL MUST BE ATTAINED ACCORDING TO THE LOCAL AUTHORITY STANDARDS PRIOR TO PROBATIONARY ACCEPTANCE. THE CONTRACTOR SHALL SUBMIT COMPACTION TEST RESULTS TO THE DESIGN ENGINEER, THE DISTRICT ENGINEER AND LOCAL JURISDICTION AS REQUIRED.
2. THE CONTRACTOR SHALL PROVIDE AS-BUILT ELEVATIONS TO THE DESIGN ENGINEER WHICH REPRESENTS THE CONSTRUCTED ELEVATIONS AND LENGTHS OF THE SANITARY SEWER AND UNDERDRAIN SYSTEMS. THE DESIGN ENGINEER WILL THEN FURNISH RECORD DRAWINGS TO THE SOUTHWEST SUBURBAN DENVER WATER & SANITATION DISTRICT PRIOR TO PROBATIONARY ACCEPTANCE, IN ACCORDANCE WITH THE DISTRICTS RULES BS REGULATIONS, AS EXPLAINED IN NOTES 1 THROUGH 4 OF THE WASTE WATER MANAGEMENT DIVISION'S "AS BUILT" NOTES.
3. THE CONTRACTOR SHALL AIR PRESSURE TEST 100% OF THE SEWER IN THE PRESENCE OF THE DISTRICT ENGINEER AFTER BACKFILLING IN ACCORDANCE WITH THE DISTRICT SPECIFICATIONS PRIOR TO PROBATIONARY ACCEPTANCE.
4. FINAL ACCEPTANCE OF THE SANITARY SEWER SYSTEM WILL OCCUR AT THE LATTER OF THE FOLLOWING. THE END OF THE ONE YEAR WARRANTY PERIOD OR 60 DAYS AFTER FINAL PAVEMENT. IF PROBATIONARY ACCEPTANCE BEGINS PRIOR TO PAVING, THE DISTRICT'S ENGINEER CONSULTANTS, WILL PROVIDE INSPECTION SERVICES IMMEDIATELY FOLLOWING ASPHALT PLACEMENT TO VERIFY ACCEPTABILITY OF THE SYSTEM.
5. AT LEAST 8 MONTHS AFTER THE PROBATIONARY ACCEPTANCE BUT NO LATER THAN 30 DAYS PRIOR TO FINAL ACCEPTANCE, THE CONTRACTOR SHALL PERFORM, IN THE PROCESS OF THE DISTRICT ENGINEER, A 5% DIAMETER DEFLECTION TEST AND CCTV INSPECTION. ALL PIPE EXCEEDING THIS DEFLECTION SHALL BE RE-LAID OR REPLACED PRIOR TO FINAL ACCEPTANCE BY THE DISTRICT, AT THE CONTRACTOR'S EXPENSE

DRAWING LOCATION: G:\Willis\14.0350-Southwest-Suburban-Denver-WSD\BASE\DETAILS\KARRISSA NOTES.dwg

GENERAL NOTES

NO.	REVISIONS	DATE	BY
1	GENERAL	7/14	JVM



SOUTHWEST SUBURBAN DENVER WATER AND SANITATION DISTRICT

NO EXCEPTIONS TAKEN _____ MAKE CORRECTIONS NOTED

REJECTED

REVISE AND RESUBMIT

SUBMIT SPECIFIED ITEM

FOR PURPOSES OF THIS REVIEW, IT IS ASSUMED THAT THE DESIGN PROFESSIONAL WHOSE REGISTRATION STAMP APPEARS ON THE DRAWINGS HAS PREPARED THE DESIGN INCLUDING SPECIFICATIONS, IF ANY, IN ACCORDANCE WITH THE APPROPRIATE STANDARD OF CARE FOR THE PARTICULAR PROJECT. THE DISTRICT'S ENGINEER CONSULTANTS HAS MADE A GENERAL REVIEW IN AN EFFORT TO ASCERTAIN WHETHER THE SUBMISSION COMPLIES WITH THE SOUTHWEST SUBURBAN DENVER WATER & SANITATION DISTRICT'S APPLICATION CRITERIA. NO DETAILED OR EXTENSIVE DESIGN REVIEW HAS BEEN MADE. UNDER NO CIRCUMSTANCES SHALL THE DISTRICT'S ENGINEER CONSULTANTS HAVE ANY LIABILITY OR RESPONSIBILITY WHATSOEVER FOR THE DESIGN OR CONSTRUCTION OF THE IMPROVEMENTS DESCRIBED IN THE SUBMISSION. THE REVIEW AND/OR COMMENTS UPON THIS SUBMISSION IS SOLELY FOR THE USE AND BENEFIT OF THE SOUTHWEST SUBURBAN DENVER WATER & SANITATION DISTRICT AND ALTHOUGH THE DISTRICT'S ENGINEER CONSULTANTS IN ITS DISCRETION MAY OBSERVE SOME ASPECTS OF THE CONSTRUCTION, THE DISTRICT'S ENGINEER CONSULTANTS DOES NOT APPROVE OR COMMENT UPON CONSTRUCTION MEANS, METHODS, SEQUENCES, AND TECHNIQUES. NO SOILS OR GEOTECHNICAL ANALYSIS HAS BEEN MADE BY THE DISTRICT'S ENGINEER CONSULTANTS

DRAWING LOCATION: G:\Willis\14.0350-Southwest-Suburban-Denver-MSD\BASE\DETAILS\KARRISA\nOTES.dwg

NO.	REVISIONS	DATE	BY
1	GENERAL	7/14	JVM



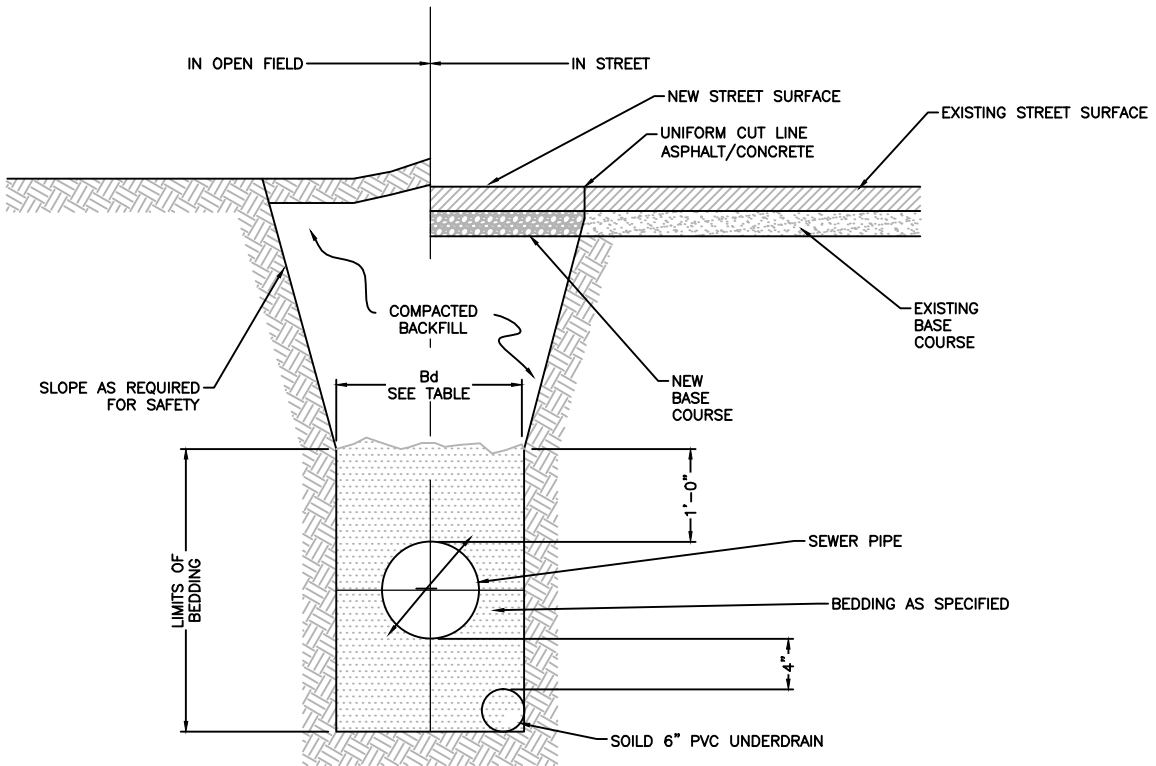

NOTE:
 COMPACT BACKFILL TO 95%
 STANDARD PROCTOR, OR PROVIDE
 FLOWABLE-FILL OVER PIPE BEDDING
 TO TOP-SOIL/BASE COURSE.

TRENCH WIDTH (Bd)		
PIPE SIZE (Bd)	MINIMUM	MAXIMUM
8"-10"	2'-0"	4'-0"
12"-16"	2'-2"	4'-6"
18"-21"	2'-6"	5'-0"
24"	3'-0"	5'-6"

SEWER BEDDING MATERIAL GRADATION	
NOMINAL SIEVE SIZE	% PASSING BY WEIGHT
1"	100
3/4"	90-100
3/8"	20-55
NO.4	0-10
NO.8	0-5

S-1

TYP. SAN SEWER

NO.	REVISIONS	DATE	BY
1	GENERAL	7/14	JVM

Southwest Suburban Denver
 Water & Sanitation District

DRAWING LOCATION: G:\Willis\14.0350-Southwest_Suburban_Denver_WSD\BASE_DETAILS\KARRISA\TYP_SAN_SEWER.dwg

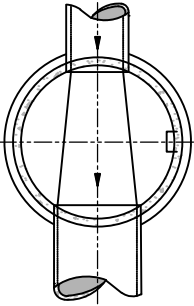

THROUGH PIPE

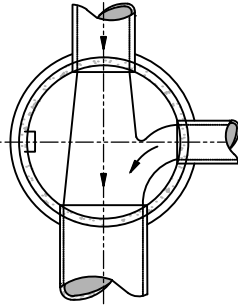

THROUGH PIPE
ONE COLLECTION LINE

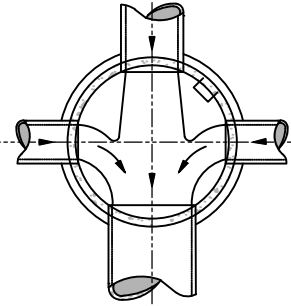

THROUGH PIPE
TWO COLLECTION LINES

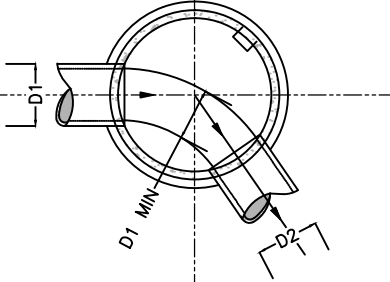

INTERMEDIATE ANGLE

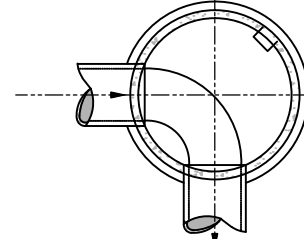

SHARP ANGLE

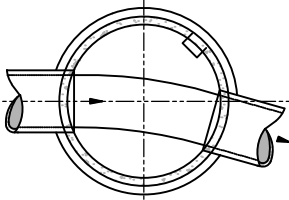

SLIGHT ANGLE

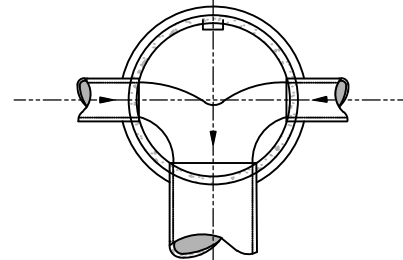

OPPOSED LATERALS

S-2

BASE CHANNELIZATION

DRAWING LOCATION: G:\Willis\14.0350-Southwest_Suburban_Denver_WSD\BASE_DETAILS\KARRISA\BASE_CHANNELIZATION.dwg

NO.	REVISIONS	DATE	BY
1	GENERAL	7/14	JVM

Southwest Suburban Denver
Water & Sanitation District

DRAWING LOCATION: G:\Willis\14.0350-Southwest_Suburban_Denver_WSD\BASE_DETAILS\KARRISA\MANHOLE.dwg

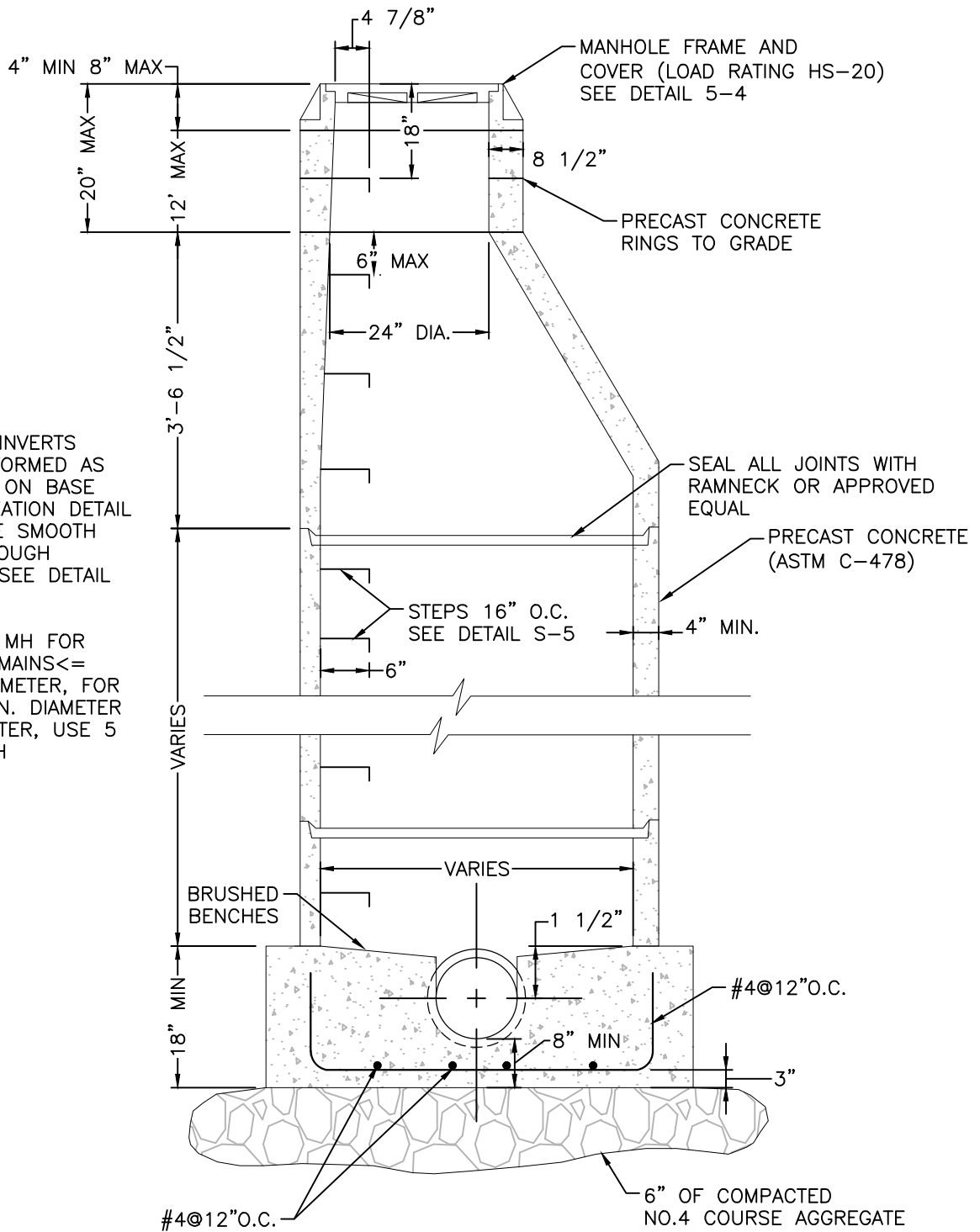

NOTE:

1. MANHOLE INVERTS WILL BE FORMED AS INDICATED ON BASE CHANNELIZATION DETAIL TO INSURE SMOOTH FLOW THROUGH MANHOLE SEE DETAIL S-2
2. 4 FT. DIA MH FOR SANITARY MAINS <= 12 IN. DIAMETER, FOR MAIN 15 IN. DIAMETER AND GREATER, USE 5 FT. DIA MH

S-3

MANHOLE

NO.	REVISIONS	DATE	BY
1	GENERAL	7/14	JVM

Southwest Suburban Denver

Water & Sanitation District

DRAWING LOCATION: G:\Willis\14.0350-Southwest-Suburban-Denver-MSD\BASE\DETAILS\KARRISA\MANHOLE_RING_AND_COVER.dwg

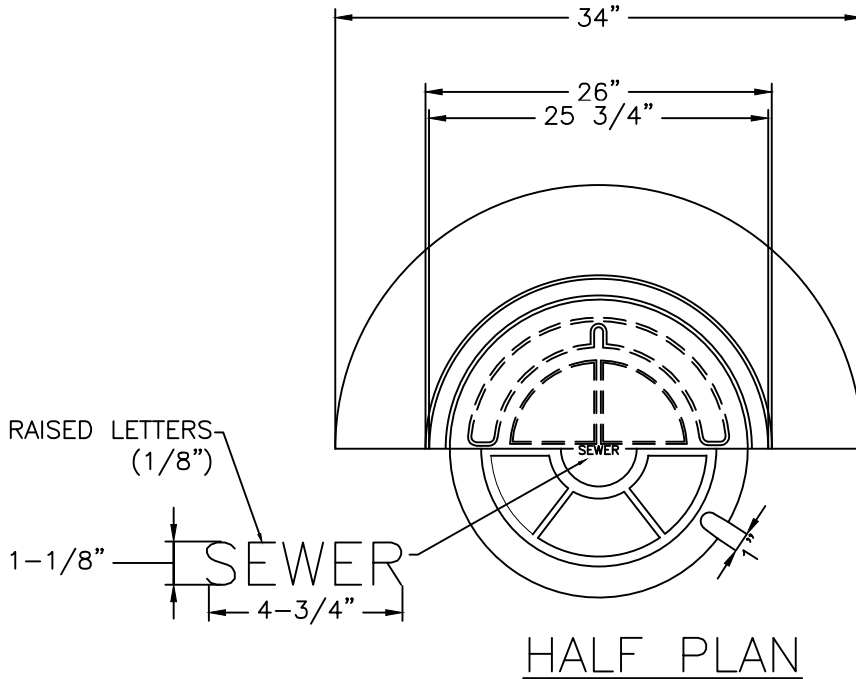

MINIMUM DESIGN
HS-20 LOADING

MINIMUM WEIGHT

4" RING	8" RING
RING= 165	235
COVER=165	165
TOTAL 330LBS 400LBS	

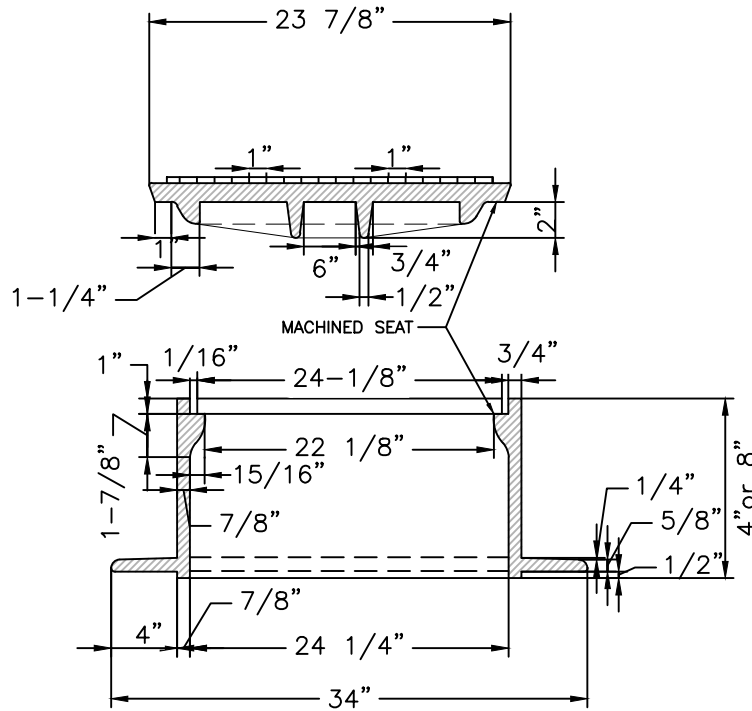

S-4

MANHOLE RING AND COVER

NO.	REVISIONS	DATE	BY
1	GENERAL	7/14	JVM



Southwest Suburban Denver
Water & Sanitation District

DRAWING LOCATION: G:\Wpfiles\14-0350--Southwest-Suburban-Denver-WSD\BASE\DETAILS\KARRISA\MANHOLE_STEPS.dwg

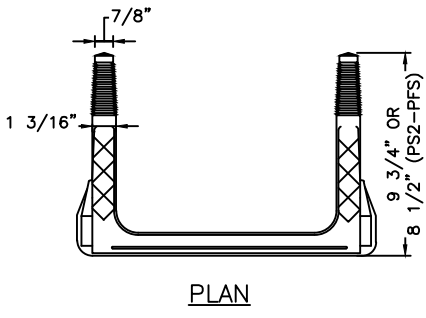

PLAN

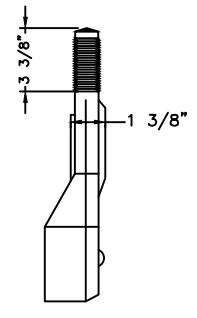

END VIEW

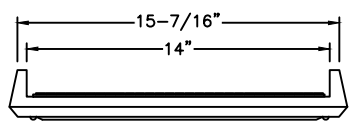

ELEVATION

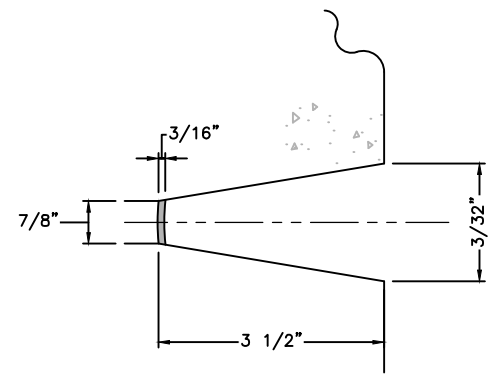

DETAIL PIN BLOCK OUT

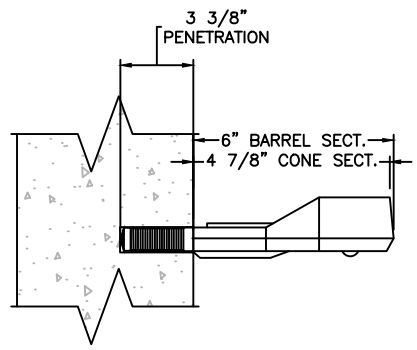

DETAIL NTS

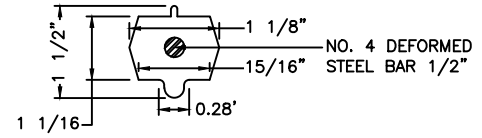

SECTION NTS

POLYPROPYLENE REINFORCED STEP

NOTES:

1. ASTM SPECIFICATION
 - A. ASTM C-478
 - B. ASTM A-615 GRADE 80 (STEEL REBAR)
 - C. ASTM 2148-69, TYPE II, GRADE 16906 (POLYPROPYLENE)
2. STEPS INSTALLED IN MANHOLE BARREL SECTIONS OF VERTICAL WALLS OF STRUCTURES SHALL HAVE 9 3/8" LEG AND SHALL PROJECT FROM THE WALL 6 INCHES.
3. STEPS INSTALLED IN MANHOLE CONE SECTIONS SHALL HAVE AN 8 1/2" LEG AND SHALL PROJECT FROM WALL 4 7/8".
4. ALL STEPS SHALL HAVE A PENETRATION DEPTH INTO WALL OF 3 3/8".
5. STEPS SHALL BE INSTALLED BY THE "PRESS-FIT" METHOD UTILIZING A SPECIALLY TAPERED PIN TO FORM THE INSERT HOLE AS SHOWN, FOLLOWING MANUFACTURE'S RECOMMENDED PROCEDURE AND SHALL NOT BE GROUTED IN PLACE
6. INSTALLED STEPS SHALL BE CAPABLE OF WITHSTANDING A PULLOUT FORCE OF 2500 LB PER LEG FOR A MINIMUM PERIOD OF TWO MINUTES.
7. PINS MUST BE SMOOTH AND CONTINUOUSLY TAPERED. DIMENSIONS OF THE PIN AND THE INSERTED PORTION OF THE MANHOLE STEP ARE TYPICALLY ONLY. W.M.D. INSTALLATION REQUIRED A MATCHED COMBINATION OF A TAPERED INSERT PIN AND MANHOLE STEP, AS RECOMMENDED OF REQUIRED BY SPECIFIC MANUFACTURER OF THE STEP TO BE USED.
8. THIS STEP CAN ALSO BE USED IN TOE POCKET INSTALLATIONS PROVIDED 5" TOE CLEARANCE IS ALLOWED.

S-5

MANHOLE STEPS

NO.	REVISIONS	DATE	BY
1	GENERAL	7/14	JVM

Southwest Suburban Denver
Water & Sanitation District

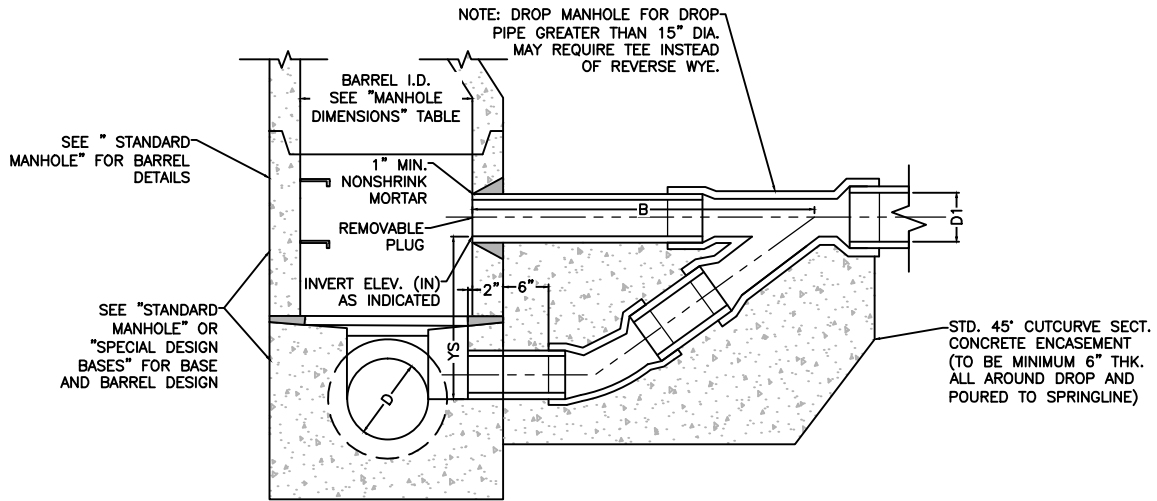

SHALLOW DROP MANHOLE
NTS

D1	A	B	YD MIN	YS MIN
8	42	41	31	18
10	47	43	37	18
12	49	51	39	22
15	65	61	55	28

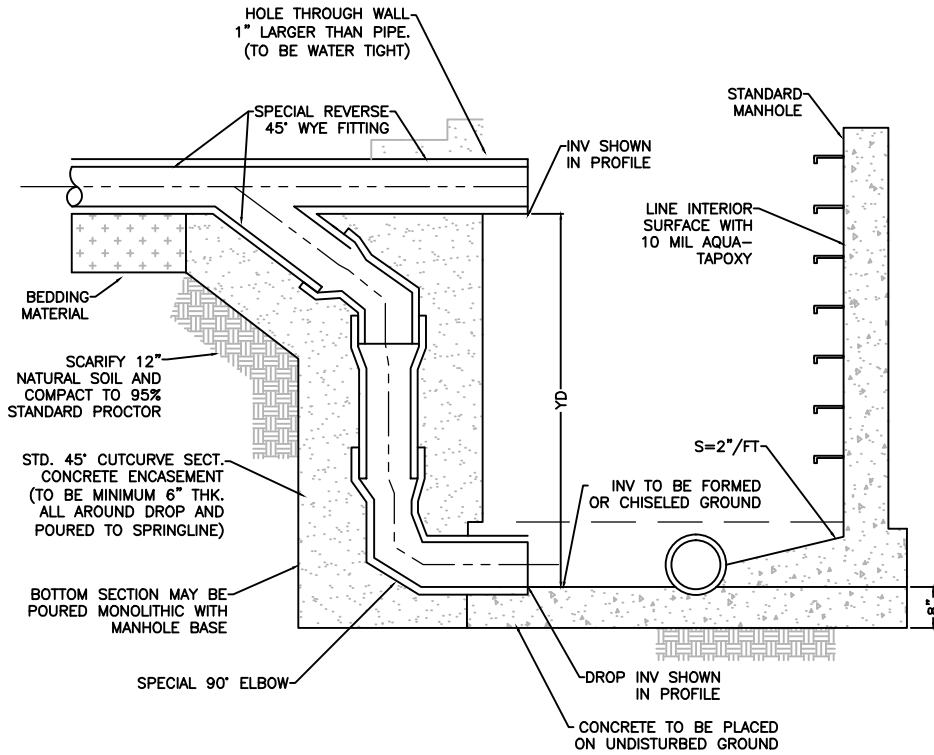

NOTE: WALL OPENING SHALL BE PRECAST BLOCKOUT IF NEW MANHOLE, OR CORD IF EXISTING MANHOLE. JACK HAMMERING NOT ALLOWED

EXTERIOR DROP TYPE MANHOLE
NTS

S-6

DROP MANHOLE

NO.	REVISIONS	DATE	BY
1	GENERAL	7/14	JVM



Southwest Suburban Denver
Water & Sanitation District

DRAWING LOCATION: G:\Willis\14.0350-Southwest_Suburban_Denver_WSD\BASE_DETAILS\KARRISA_DROP_MANHOLE.dwg

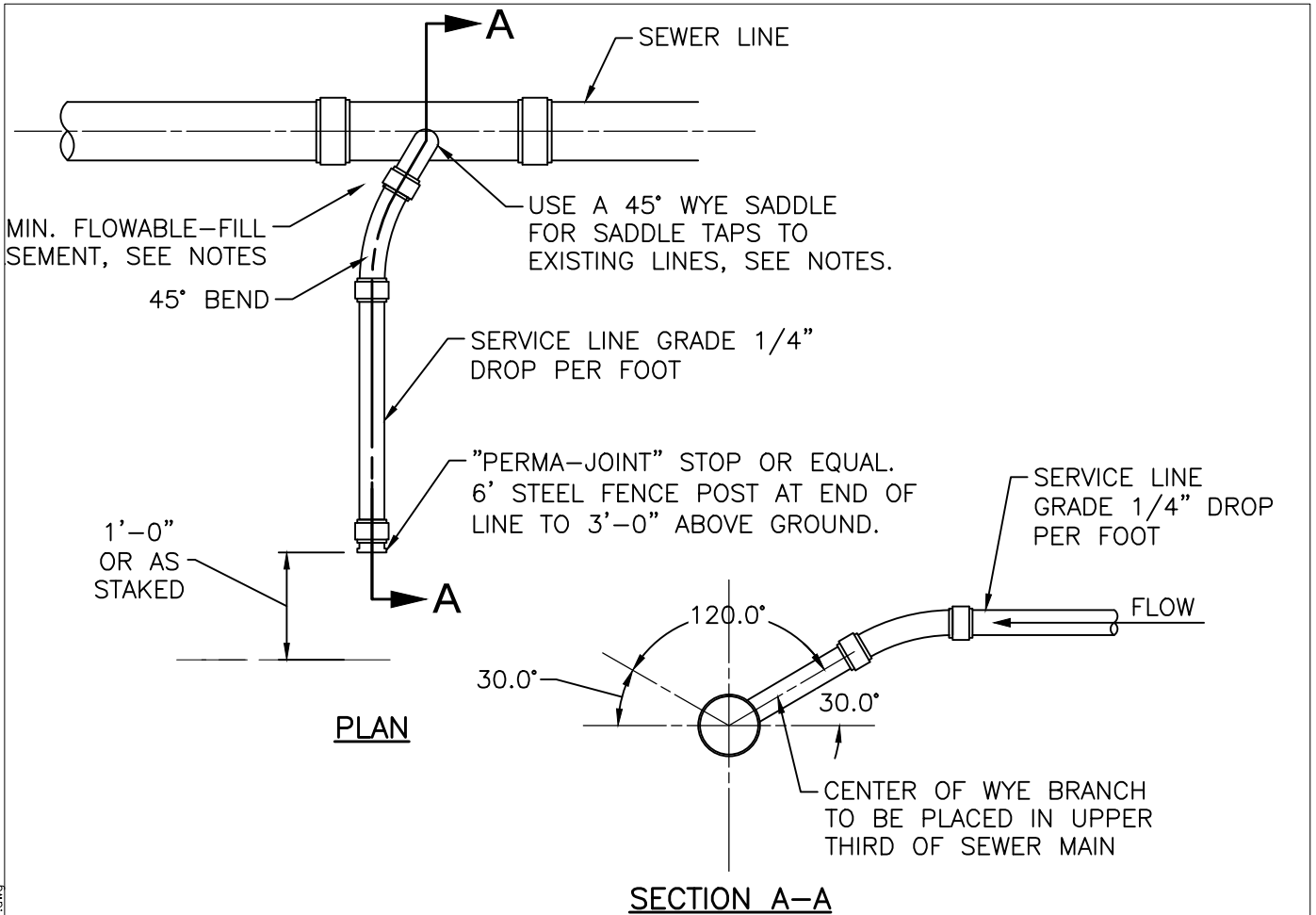

NOTES:

SEWER SERVICES CONNECTIONS SHALL BE POSITIONED AT EITHER THE 2 O'CLOCK OR THE 10 O'CLOCK POSITION OF THE CIRCUMFERENCE OF THE SEWER MAIN. ON NEW INSTALLATIONS, ONLY WYE FITTINGS SHALL BE USED. WHEN TAPPING INTO AN EXISTING SEWER MAIN, A WYE SADDLE CONNECTION AND DISTRICT ENGINEER APPROVED CORING METHOD SHALL BE USED. ALL SADDLE CONNECTIONS SHALL HAVE SERIES 300 STAINLESS STEEL STRAPS AND OTHER HARDWARE. THE MINIMUM DISTANCE BETWEEN SERVICE CONNECTIONS MADE ALONG THE PIPE SHALL BE 3- FEET. THE MINIMUM DISTANCE FROM EITHER THE BELL OR SPIGOT END OF PIPE SHALL BE 3- FEET. THE MINIMUM DISTANCE FROM CENTER OF A MANHOLE TO A SERVICE CONNECTION SHALL BE EITHER 5- FEET OF THE TRANSITION POINT FROM THE MANHOLE TRENCH TO THE NORMAL PIPE TRENCH, WHICHEVER IS GREATER. A MAXIMUM OF 4 SEWER SERVICES CONNECTIONS SHALL BE ALLOWED ALONG A 20- FOOT LENGTH OF PIPE. IN ALL CASES, A SPECIFIC SOILS INVESTIGATION SHOULD BE CONDUCTED TO ASSURE THAT THE EXTERNAL LOADING WILL BE WITH IN ALLOWABLE LIMITS REGARDLESS OF THE NUMBER OF TAPS INVOLVED. ALL SERVICE CONNECTIONS SHALL BE ENCASED IN A MINIMUM OF 6- INCHES OF FLOWABLE- FILL MATERIAL. FLOWABLE- FILL SHALL HAVE A MINIMUM STRENGTH OF 50 PSI AFTER CURING 28 DAYS.

S-7

**DOMESTIC
SEWER TAP**

NO.	REVISIONS	DATE	BY
1	GENERAL	7/14	JVM



DRAWING LOCATION: G:\Willis\14_0350-Southwest-Suburban-Denver-MSD\BASE\DETAILS\KARRISA\S-7 - DOMESTIC SEWER TAP.dwg

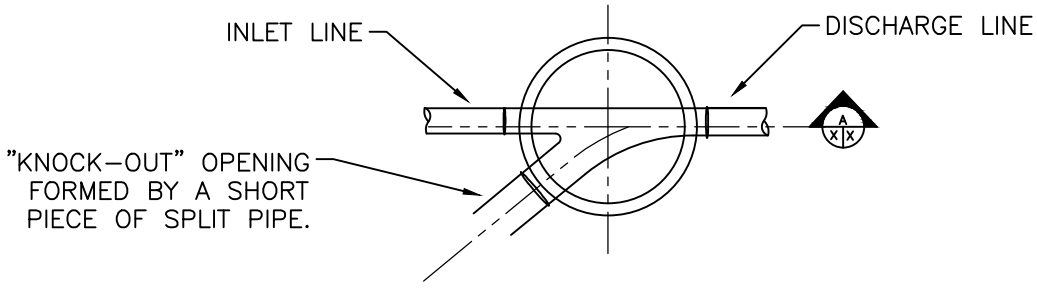

PLAN VIEW

NOTE: "KNOCK-OUT" OPENING IN BASE SHALL BE FORMED WITH A SHORT PIECE OF "SPLIT PIPE" AND BENCH FORMED ACCORDINGLY. THE PIPE SHALL BE A MINIMUM OF 12" DIA. OF 3" LARGER THAN THE DISCHARGE LINE SIZE. AN "O" RING GASKET "KEY" FOR USE WHEN THE FUTURE PIPE IS CONSTRUCTED. AFTER THE CONCRETE HAS BEEN SET THE "SPLIT PIPE" SHALL BE BROKEN OUT AND THEN CLOSED WITH BRICK AND MORTAR.

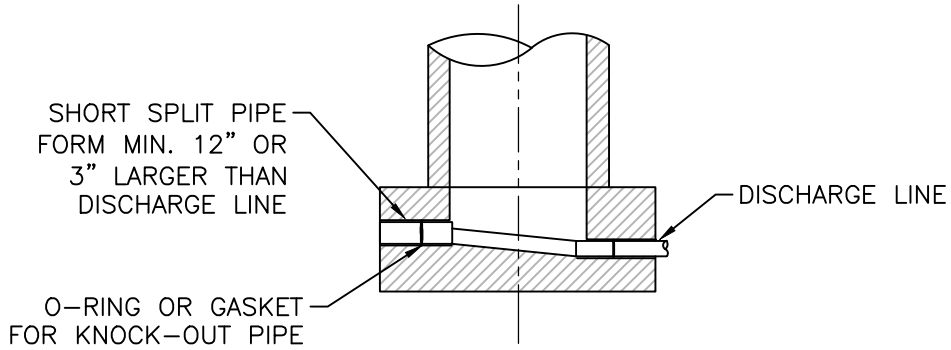

SECTION A

S-8

**KNOCK-OUT
MANHOLE**

NO.	REVISIONS	DATE	BY
1	GENERAL	7/14	JVM

Southwest Suburban Denver
Water & Sanitation District